

**HC** HYDRAULIC CRANE  
**INDUSTRIE**

# HC 190 JIB L-M-S



I MIGLIORI PRODOTTI DI QUALITÀ | BEST QUALITY PRODUCTS

[www.hcindustrie.com](http://www.hcindustrie.com)

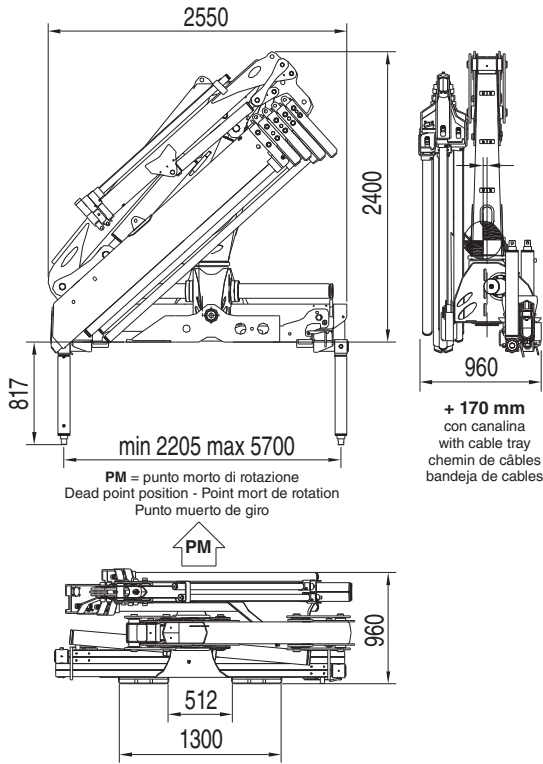

**GRU STANDARD JIB JIB Std Crane - Grue Standard JIB - Grua standard JIB**

<b>Bracci stabilizzatori extra estensibili manuali</b> Manual extra extensible outrigger booms - Bras de stabilisation manuels extra-extensibles - Brazos estabilizadores manuales extra extensibles	<b>mm. 5700</b>
<b>Angolo di rotazione</b> Slewing angle - Angle de rotation - Giro	<b>400°</b>
<b>Tiranti di ancoraggio (kg. 50)</b> Tie rods for anchorage - Tirants d'ancrege - Tirantes de fijación	<b>n° 8 M27x2</b>
<b>Portata raccomandata</b> Recommended oil flow - Débit recommandé - Caudal requerido	<b>l/min. 40</b>
<b>Capacità del serbatoio</b> Tank capacity - Capacité du réservoir - Capacidad del depósito de aceite	<b>lt. 100</b>
<b>Pressione massima</b> Rated pressure - Pression maxi - Presión máxima	<b>bar 330</b>

<b>HC 190 A2</b>	<b>J1.L</b>	<b>J2.L</b>	<b>J3.L</b>	<b>J4.L</b>
<b>Massa della gru senza olio nel serbatoio</b> - Overhang crane without oil in the tank - Poids de la grue sans huile dans le réservoir - Peso de la grua sin aceite en el depósito	<b>Kg. 2800</b>	<b>Kg. 2850</b>	<b>Kg. 2900</b>	<b>Kg. 2950</b>
<b>Momento di sollevamento massimo JIB</b> - Maximum JIB lifting moment - Moment de levage maxi JIB - Momento de elevación máxima JIB	<b>tm 13,27</b>	<b>tm 12,85</b>	<b>tm 12,42</b>	<b>tm 11,98</b>
<b>Sbraccio oleodinamico</b> - Maximum hydraulic reach - Déport hydraulique - Alcance hidráulico				
<b>Orizzontale</b> Horizontal - Horizontal - Horizontal	<b>m. 11,81</b>	<b>m. 13,48</b>	<b>m. 15,15</b>	<b>m. 16,82</b>
<b>Verticale</b> Vertical - Vertical - Vertical	<b>m. 15,31</b>	<b>m. 16,98</b>	<b>m. 18,65</b>	<b>m. 20,32</b>

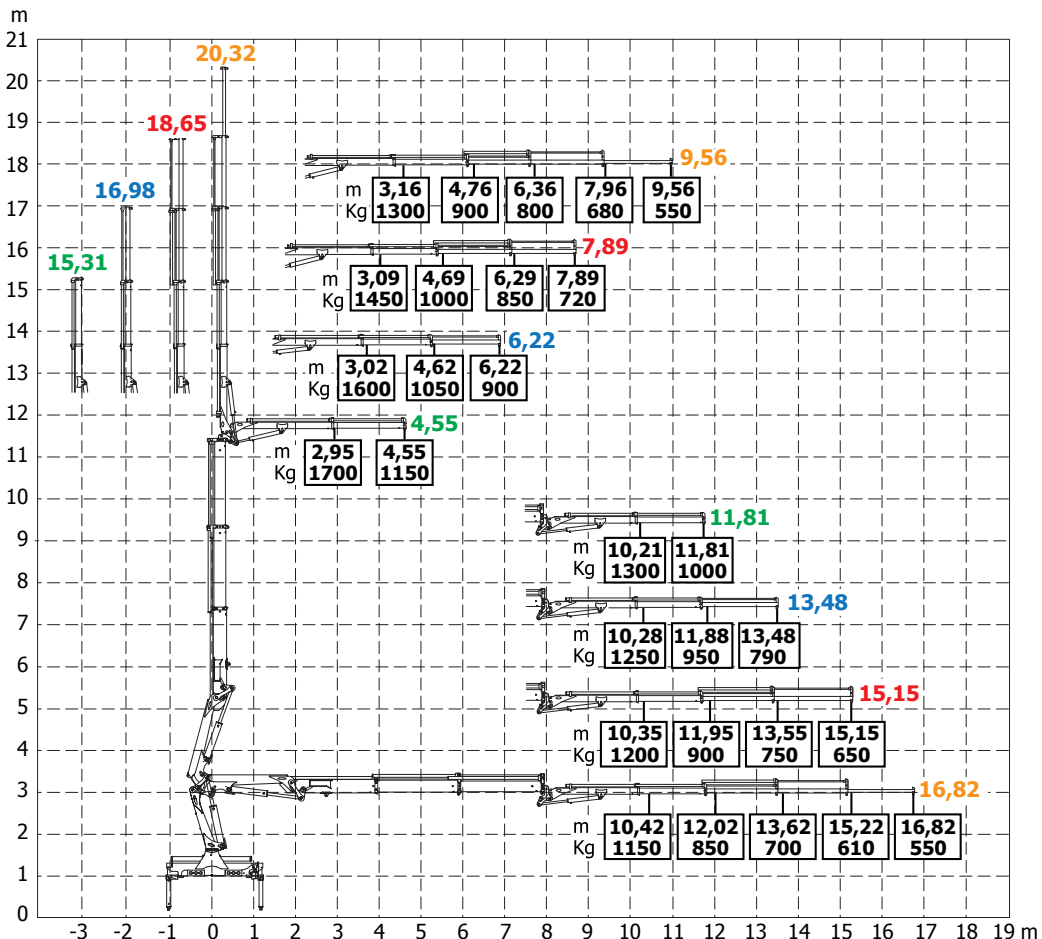

HC 190 A3	J1.L	J2.L	J3.L	J4.L
<b>Massa della gru senza olio nel serbatoio</b> - Overhang crane without oil in the tank - Poids de la grue sans huile dans le réservoir - Peso de la grua sin aceite en el depósito	Kg. 2950	Kg. 3000	Kg. 3050	Kg. 3100
<b>Momento di sollevamento massimo JIB</b> - Maximum JIB lifting moment - Moment de levage maxi JIB - Momento de elevación máxima JIB	tm 15,26	tm 14,74	tm 14,20	tm 13,66
<b>Sbraccio oleodinamico</b> - Maximum hydraulic reach - Déport hydraulique - Alcance hidráulico	m. 13,81	m. 15,48	m. 17,15	m. 18,81
<b>Orizzontale</b> Horizontal - Horizontal - Horizontal	m. 17,31	m. 18,98	m. 20,65	m. 22,31
<b>Verticale</b> Vertical - Vertical - Vertical				

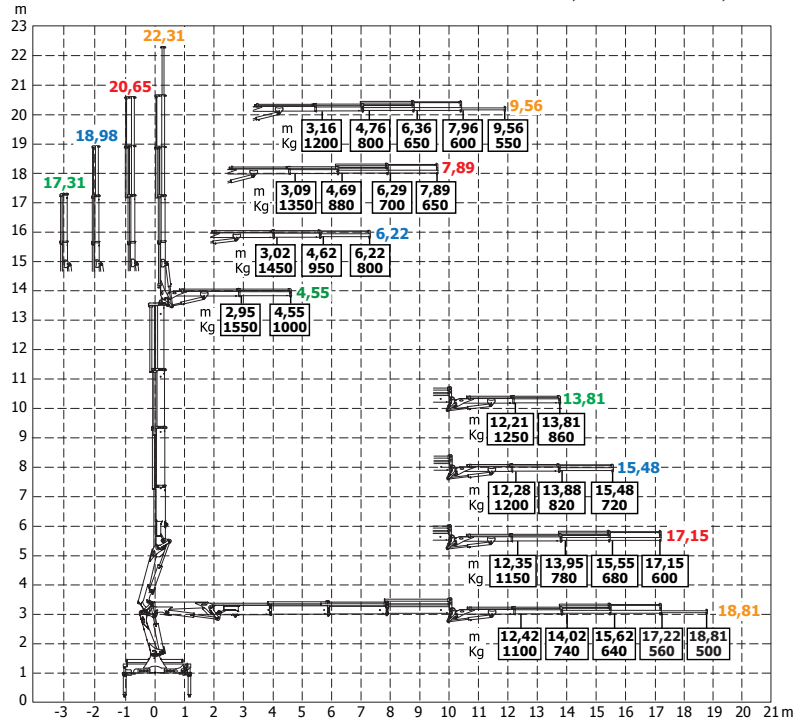

HC 190 A4	J1.L	J2.L	J3.L	J4.L
<b>Massa della gru senza olio nel serbatoio</b> - Overhang crane without oil in the tank - Poids de la grue sans huile dans le réservoir - Peso de la grua sin aceite en el depósito	Kg. 3150	Kg. 3200	Kg. 3250	Kg. 3300
<b>Momento di sollevamento massimo JIB</b> - Maximum JIB lifting moment - Moment de levage maxi JIB - Momento de elevación máxima JIB	tm 11,35	tm 10,70	tm 10,03	tm 9,36
<b>Sbraccio oleodinamico</b> - Maximum hydraulic reach - Déport hydraulique - Alcance hidráulico	m. 15,79	m. 17,46	m. 19,13	m. 20,80
<b>Orizzontale</b> Horizontal - Horizontal - Horizontal	m. 19,29	m. 20,96	m. 22,63	m. 24,30
<b>Verticale</b> Vertical - Vertical - Vertical				

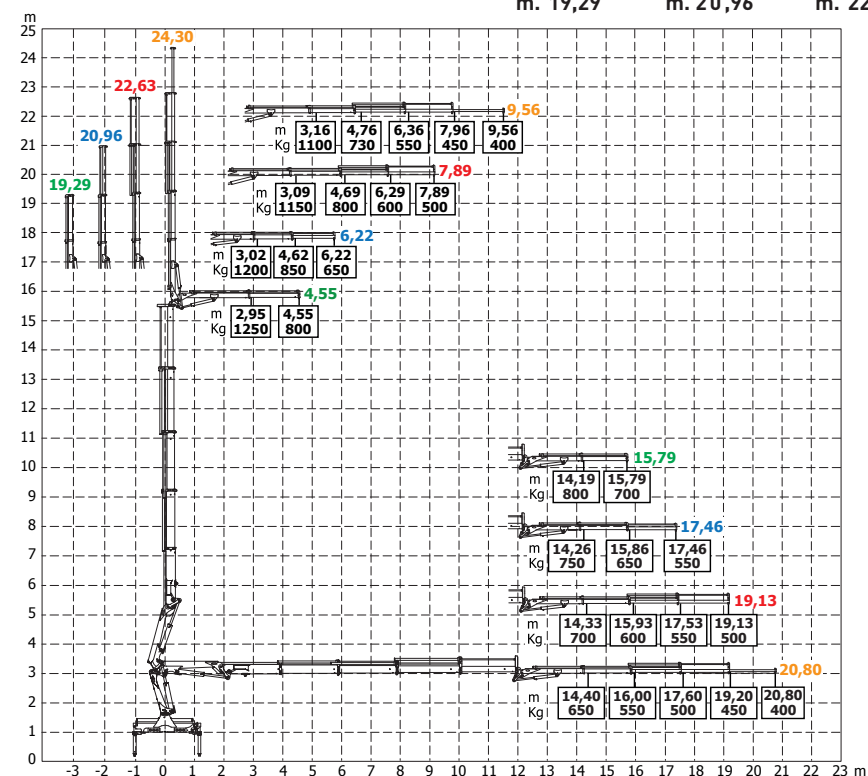

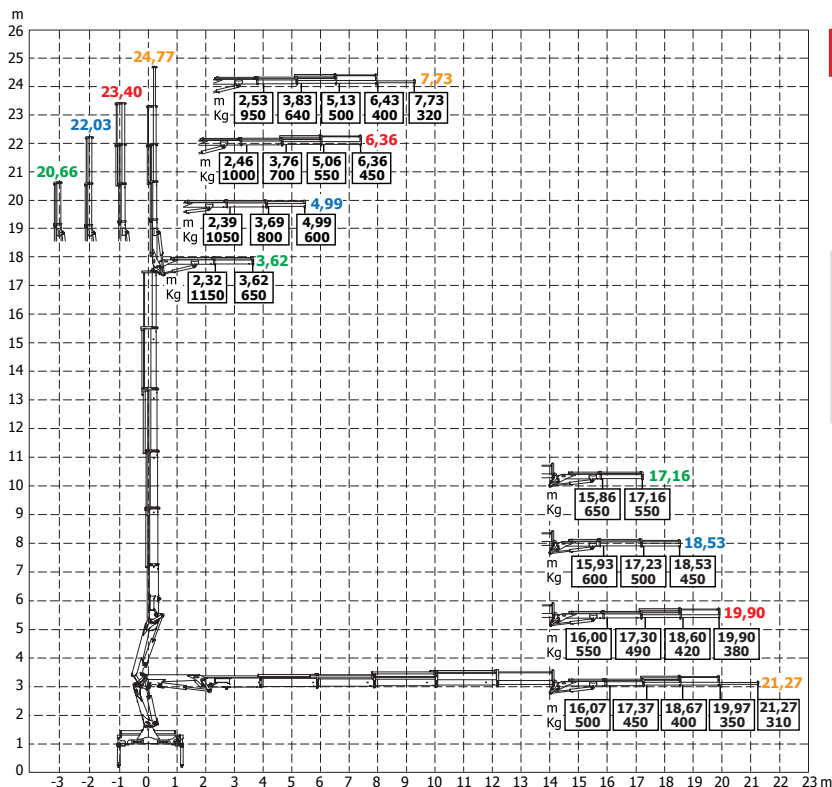

**HC 190 A5** J1.M J2.M J3.M J4.M

**Massa della gru senza olio nel serbatoio** - Overhang crane without oil in the tank - Poids de la grue sans huile dans le réservoir - Peso de la grua sin aceite en el depósito

	J1.M	J2.M	J3.M	J4.M
<b>Kg.</b>	3000	3050	3100	3150

**Momento di sollevamento massimo JIB** - Maximum JIB lifting moment - Moment de levage maxi JIB - Momento de elevación máxima JIB

	J1.M	J2.M	J3.M	J4.M
<b>tm</b>	10,30	9,56	8,80	8,03

**Sbraccio oleodinamico** - Maximum hydraulic reach - Déport hydraulique - Alcance hidráulico

	J1.M	J2.M	J3.M	J4.M
<b>m.</b>	17,16	18,53	19,90	21,27

**Orizzontale** Horizontal - Horizontal

**Verticale** Vertical - Vertical

	J1.M	J2.M	J3.M	J4.M
<b>m.</b>	20,66	22,03	23,40	24,77

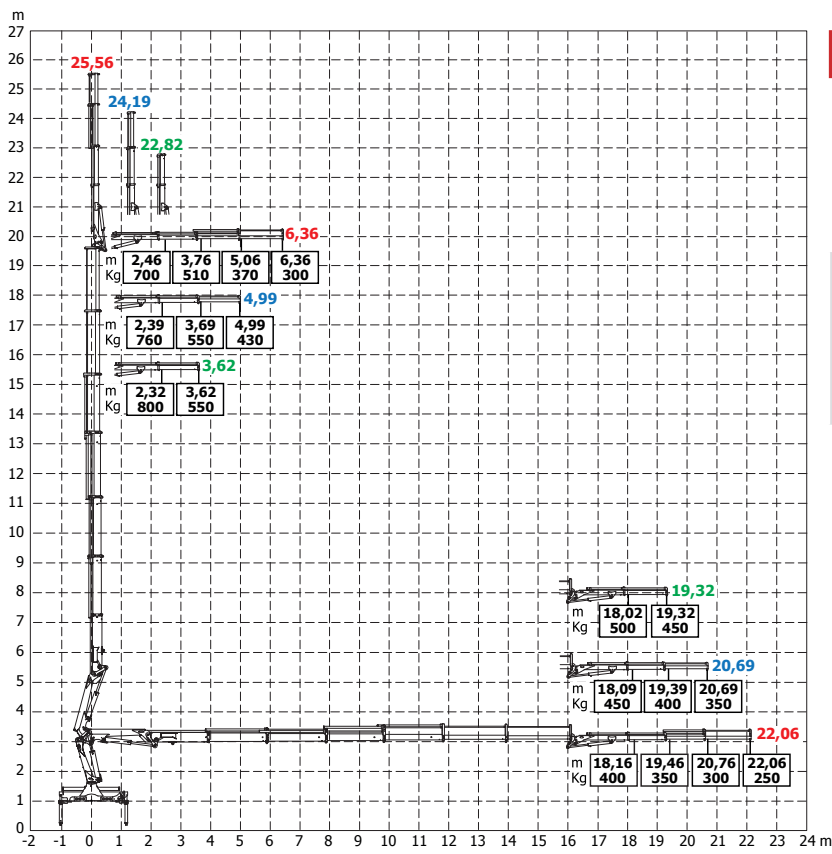

**HC 190 A6** J1.S J2.S J3.S

**Massa della gru senza olio nel serbatoio** - Overhang crane without oil in the tank - Poids de la grue sans huile dans le réservoir - Peso de la grua sin aceite en el depósito

	J1.S	J2.S	J3.S
<b>Kg.</b>	3100	3160	3200

**Momento di sollevamento massimo JIB** - Maximum JIB lifting moment - Moment de levage maxi JIB - Momento de elevación máxima JIB

	J1.S	J2.S	J3.S
<b>tm</b>	7,26	8,14	9,01

**Sbraccio oleodinamico** - Maximum hydraulic reach - Déport hydraulique - Alcance hidráulico

	J1.S	J2.S	J3.S
<b>m.</b>	19,32	20,69	22,06

**Orizzontale** Horizontal - Horizontal

**Verticale** Vertical - Vertical

	J1.S	J2.S	J3.S
<b>m.</b>	22,82	24,19	25,56

TUTTI I DATI TECNICI POSSONO ESSERE CAMBIATI SENZA PREAVVISO - ALL TECHNICAL DATA CAN BE CHANGED WITHOUT NOTICE  
 TOUS LES DONNEES TECHNIQUES PEUVENT ETRE MODIFIEES SANS PREAVIS - TODOS LOS DATOS TECNICOS PUEDEN SER CAMBIADOS SIN AVISO

**HC INDUSTRIE S.R.L.**  
 Via Luciano Romagnoli, 1  
 42023 Cadelbosco di Sopra Reggio Emilia, Z.I. La Madonnina (RE)  
 Phone +39.0522.911729 - Fax +39.0522.404040  
 Email: commerciale@hcindustrie.com - Website: www.hcindustrie.com